

TUBE FIRED FRYERS 25 LB. COUNTER TOP MODEL

IMPERIAL®

Model Number
IFST-25

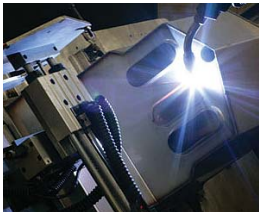

Robotic welding is precise,
virtually eliminating leaks.



IFST-25 shown with optional
stainless steel equipment stand

TUBE FIRED BURNERS - High efficiency cast iron burners have a large heat transfer area.

- Tubes are constructed of heavy gauge metal with a built-in deflector system.
- 70,000 BTU (21 KW) total output.
- Millivolt temperature control circuit.
- Snap acting thermostat has a 200° F - 400° F (93° C-204° C) temperature range.
- Fast recovery to desired temperature.
- Heats oil quickly producing a better tasting product with less oil absorption.
- 100% safety shut-off.

LARGE COOL ZONE - Captures and holds particles below the tubes, out of the fry zone.

- Reduces taste transfer.

STAINLESS STEEL FRYPOTS - Frying area for the 25 lb. model is 12-1/2" x 14" (318 x 356 mm).

- Frypot tubes and sides are robotically welded stainless steel to virtually eliminate leaks.
- Fine mesh wire crumb is included.
- Recessed bottom facilitates draining, slants toward the drain.
- 1-1/4" (32 mm) full port drain valve empties frypot quickly and safely.
- Two nickel-plated fry baskets with vinyl coated, heat protection, handles are included.
- Basket hangers are stainless steel.

EXTERIOR FEATURES - Stainless steel front, door, sides, basket hanger and frypot.

- Welded and polished stainless steel seams.
- Full heat shield protects control panel.
- Full bottom chassis provide structural support.
- Plate mounted 4" (102 mm) heavy duty stainless steel legs assures secure support.
- One year parts and labor warranty. Limited warranty on frypot, stainless steel frypot is five years pro-rated.



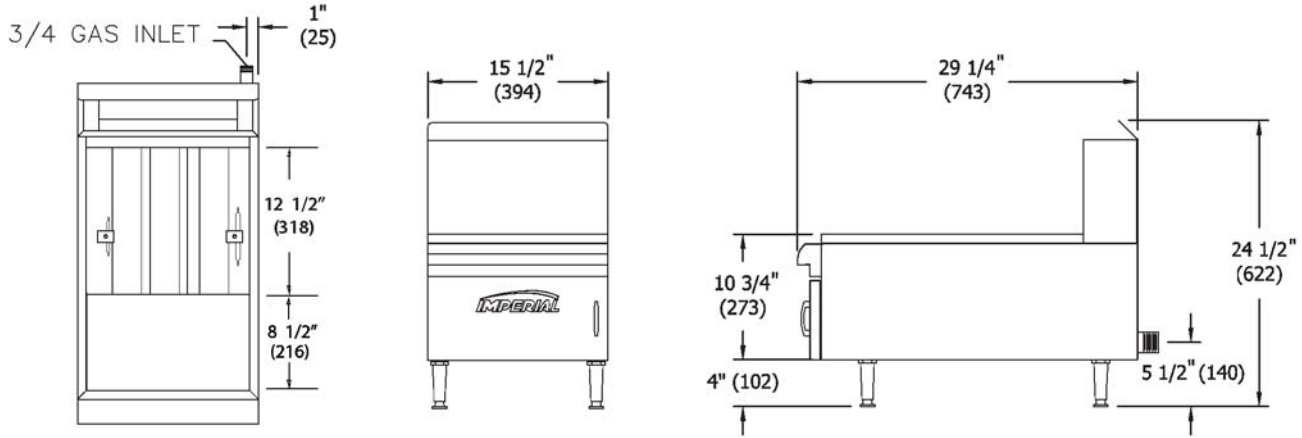

25 LB. TUBE FIRED COUNTER TOP FRYERS

MODEL	OIL CAPACITY	GAS OUTPUT		NUMBER OF BURNERS	SHIP WEIGHT	
		BTU	(KW)		(KG)	LBS
IFST-25	25 (14 L)	70,000	(21)	3	(50)	110

Measurements in () are metric equivalents.

MANIFOLD PRESSURE		MANIFOLD SIZE
NATURAL GAS	PROPANE GAS	
4.0" W.C.	11.0" W.C.	3/4"

Specify elevation, if over 2,000 ft.

MODEL	FRYING AREA	DIMENSIONS	CRATED DIMENSIONS
	IFST-25	12-1/2" x 14" (318 x 356 mm)	15-1/2" w x 29-1/4" d x 24-1/2" h (394 x 743 x 622 mm)

CLEARANCE REQUIREMENTS
 For use only on non-combustible surfaces. Provide 0" clearance from non-combustible surfaces and 6" (152 mm) from combustible surfaces.

- OPTIONS AND ACCESSORIES**
- Stainless steel equipment stand measures 16" w x 28 1/2" d x 22" h (406 x 724 x 559 mm)
 - Extra fry baskets with vinyl coated handles
 - Gas shut off valve, 3/4" N.P.T.
 - Quick disconnect and flexible gas hose, 3/4" N.P.T.
 - 6" (152 mm) casters for equipment stand



1128 Sherborn Street Corona, CA 92879
 800.343.7790 Ph: 951.281.1830 Fx: 951.281.1879
 www.imperialrange.com
 E-mail: imperialsales@imperialrange.com